

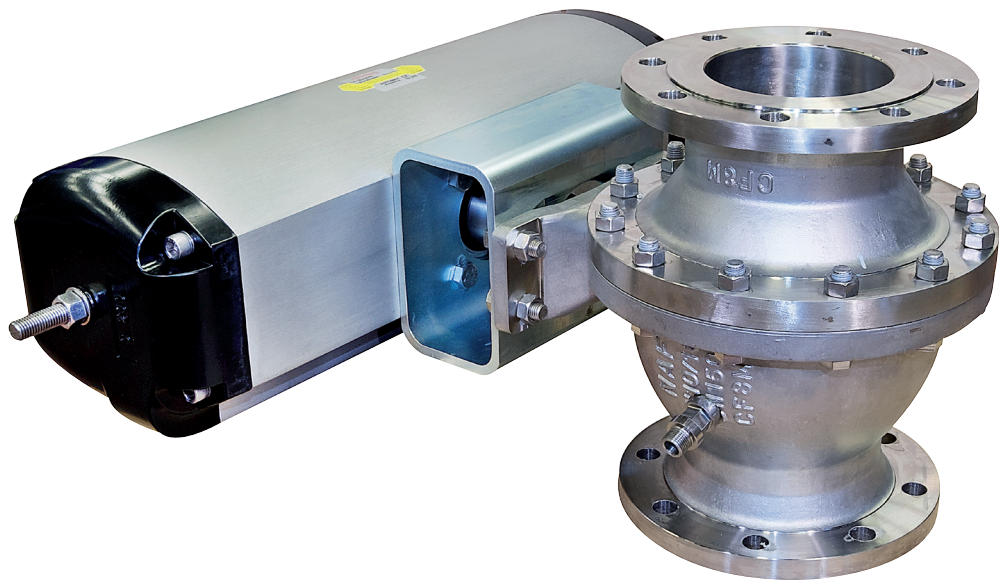

TECHNICAL BULLETIN

NAF Duball DL Pocket Ball Valves

FCD NFENTB4163-00-A4 11/17



Primary characteristics

The NAF Duball DL Pocket Valve is the pulp and paper industry’s choice for a reliable and robust valve solution that allows for safe removal of sand or debris in separator and junk trap applications during normal process operation. Building on years of experience in providing flow control solutions in harsh environments, the Duball DL Pocket Valve is specifically designed to ensure continuous process uptime and throughput by allowing process pressure to be maintained while unwanted process particles are eliminated.

The NAF Duball DL Pocket Valve is engineered to excel:

- **Longer service life via ball constructed in Solid Alloy 6** material for unmatched performance in challenging applications
- **Improved process uptime** from a reliable valve design which discharges solids while maintaining full process pressure and minimizes loss of process medium
- **Improved wear resistance with sealed and locked seats which prevent extensive wear on the ball** caused by medium build-up behind the seats
- **Minimized leakage owing to metal seats** with a rigid welded overlay of Alloy 6
- **Two flush port connections to effectively flush both the body and the ball cavity** during the discharge sequence
- Long, maintenance free and safe operation provided by a **spring loaded stem seal packing**
- **Robust, blowout-proof stem supported by a wear resistant anti-friction washer in Alloy 6** provides a high torque transmission
- An **easy-to-service arrangement**, due to the off-center joint face of the valve body, which allows for easy replacement of the ball and seals, without the need for removing the stem and actuator

CE-marked according to Pressure Equipment Directive (PED 2014/68/EU) module H, category III.

Technical specifications for standard design

Material	Stainless steel
Size range	DN 80-200, 3"-8"
Pressure ratings	PN 10-40, ANSI Class 150-300
Face to Face lengths	PN 10-16: EN558-1 series 12 (SSG 1042) PN 25-40: EN558-1 series 4 (SSG 1043) ANSI 150: ANSI B 16.10 Class 150 long ANSI 300: ANSI B 16.10 Class 300 short
Valve Design	ANSI B16.34 or EN 12 516
Installation method	Flanges to EN or ANSI B 16.5
Temperature Range	-30 - 250 °C, see graph on page 7
Test procedure	Body: 1.5 x maximum working pressure Seat: 1.1 x maximum allowed differential pressure Testing medium is water with inhibitor
Tightness class	ISO 5208 Rate D

Applications

Typical applications for the NAF Duball DL Pocket valve include sand removal under a separator or other junk trap applications. The NAF Duball DL Pocket Valve is installed on a vertical pipe allowing debris to sediment into the ball cavity.

The valve is typically automated using a pneumatic actuator with a stroke set to 140 degrees. Alternatively, a severe service electric actuator can be used for larger valves and higher differential pressures.

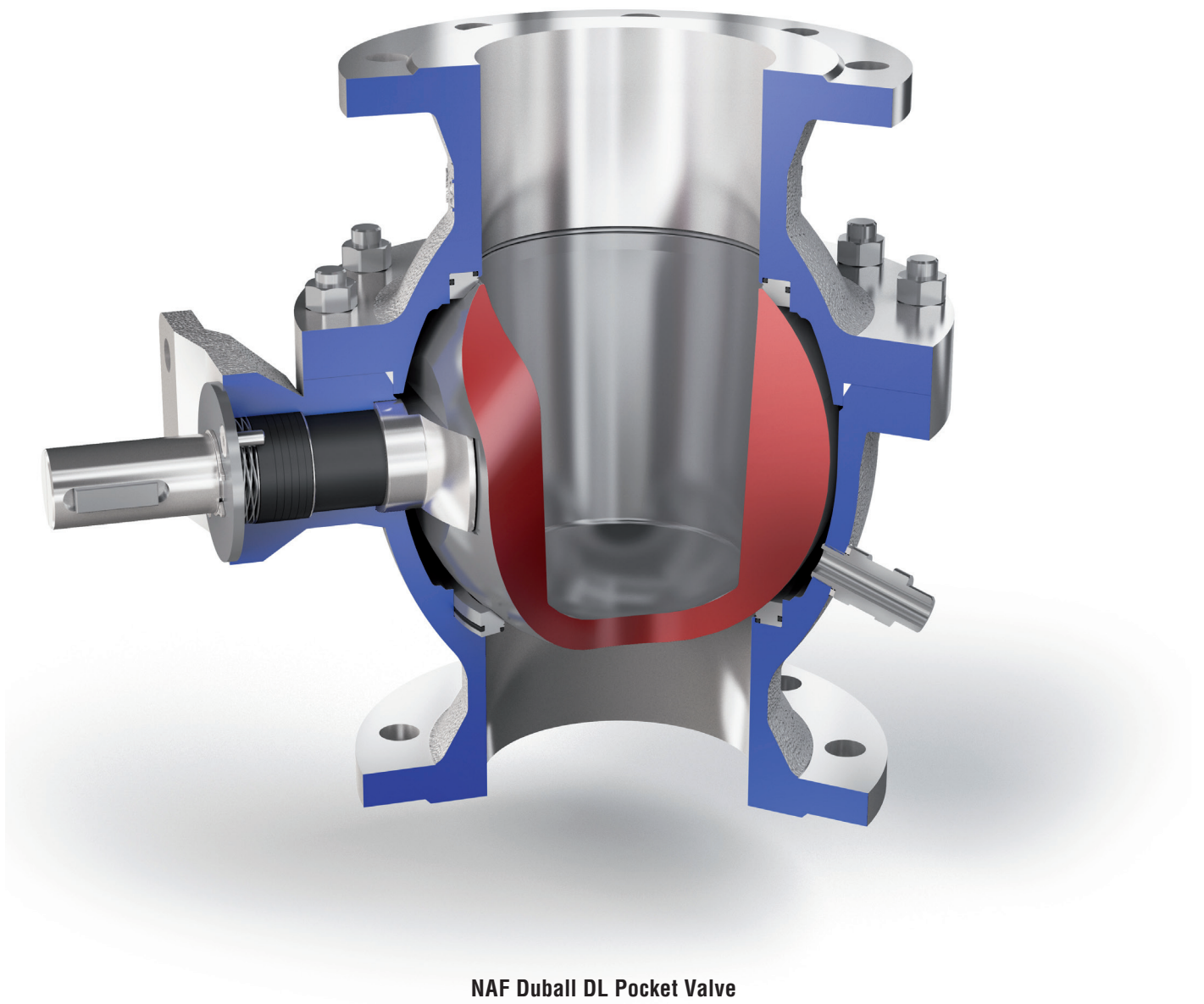

NAF Duball DL Pocket Valve

Valve sizing and flushing

In order to minimize wear and maximize lifetime, it is very important that the valve is correctly sized and flushed during the discharge sequence. Valve sizing, flushing requirements and a complete sequence description can be found in user instruction NFENTB4163.

The cut-away images show the discharge sequence together with valve flushing.

Filling mode

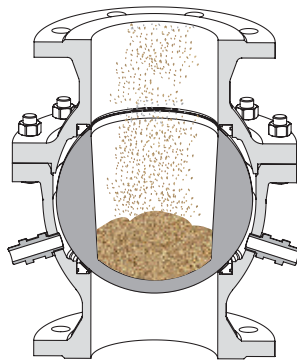

Ball under rotation - Process pressure is maintained

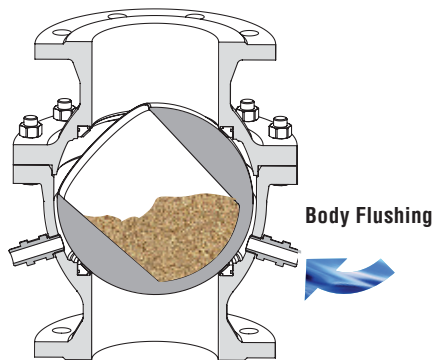

Final discharge position - Ball cavity is flushed

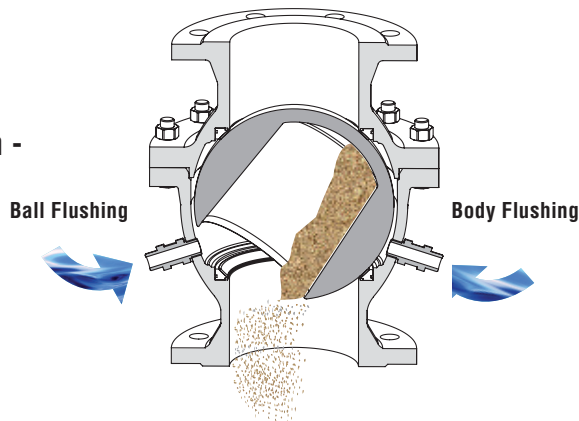

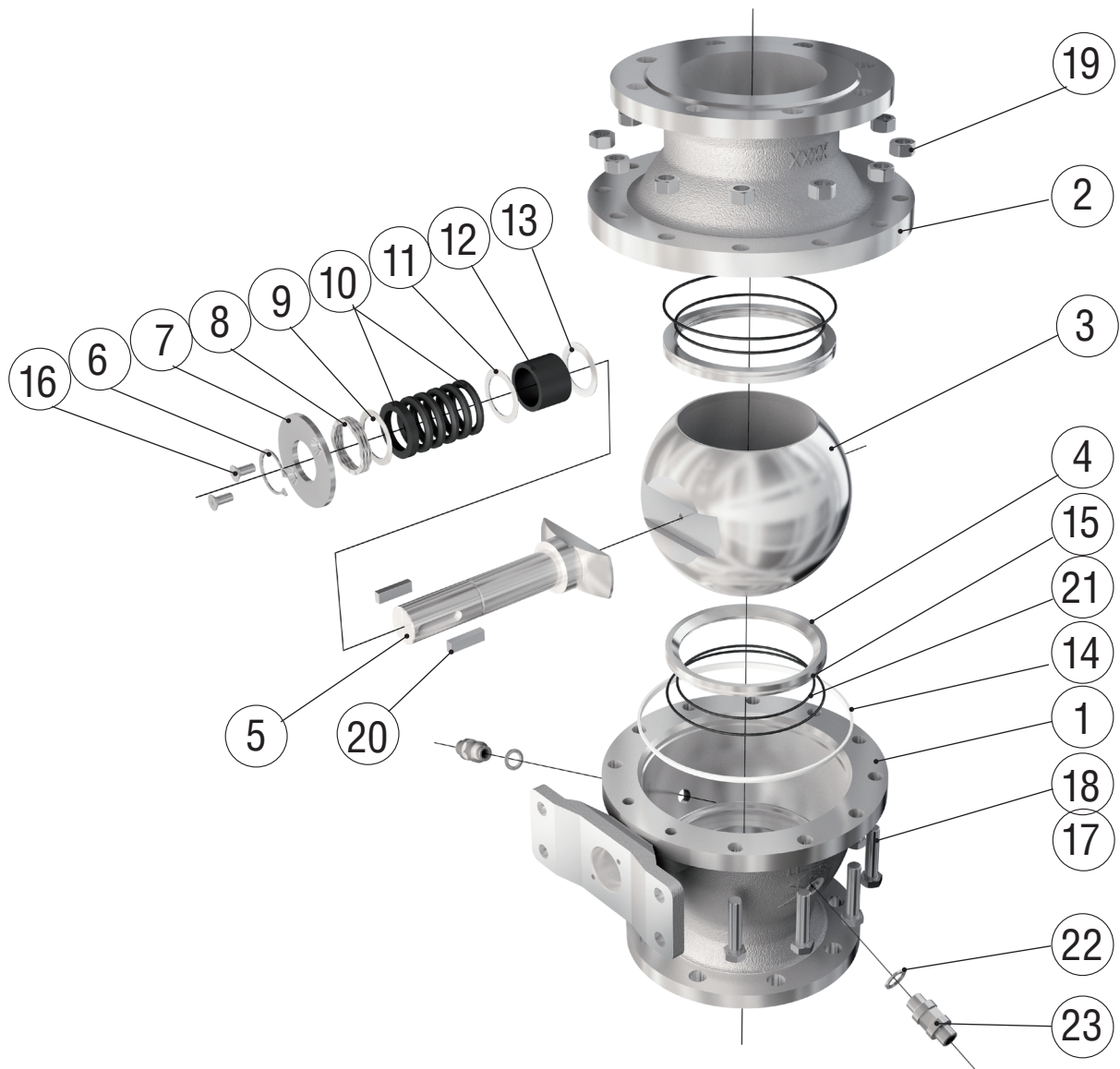

Table 1: Materials

Item	Qty	Part	Material
1	1	Body, main	CF8M / 1.4408
2	1	Body, cover	CF8M / 1.4 408
3	1	Pocket Ball	Solid Alloy 6
4	2	Seat ring	SS / Alloy 6
5	1	Stem	EN 1.4460 (type AISI 329)
6	1	Circlip	A2
7	1	Cover	AISI 316L / EN 1.4404
8	1	Spring	17-7PH
9	1	Washer	AISI 316L / EN 1.4404
10	1	Stem packing	R-PTFE carbon reinforced
11	1	Washer	AISI 316L / EN 1.4404
12	1	Bushing	R-PTFE carbon reinforced

Item	Qty	Part	Material
13	1	Anti-friction Washer	Alloy 6
14	1	Body seal	PTFE
15	2	Inside seat seal	H-ELAST
16	1)	Screw	A4
17	2	Stud	A4/ASTM A193 gr. B8M
18	1)	Bolt	A4/ASTM A193 gr. B8M
19	1)	Nut	A4/ASTM A194 gr. 8M
20	2	Key	A4
21	2	Outside seat seal	H-ELAST
22	2	Seal ring	AISI 316/EPDM
23	2	Water flushing fittings	AISI 316

1) Quantity depending on size of the valve.

Material and design of the parts vary depending on the version of the valve. Version is determined by NAF No. on the identification plate of the valve.

Seat rings

The seats are sealed and locked in place. This prevents medium build-up behind the seat and creating an increased torque over time.

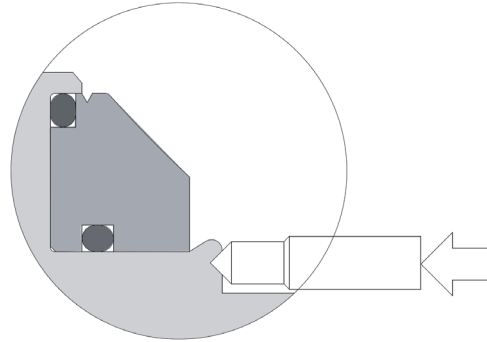

Metal seat standard – Seats are sealed and locked in place

Operating torque

Table 2 is provided for the correct sizing of an actuator. Please note the following;

- The actuator must be able to turn 140°
- Maximum allowed differential pressure according to the graphs on page 7 must be taken into consideration
- Operating torque is only valid when valve is sufficiently flushed during the discharge sequence. Please refer to the user instruction NFENIM4163

Table 2: Operating torque, Nm

DN	Size	Differential pressure in bar				
		5	10	16	20	25
80	3"	130	218	323	393	480
100	4"	230	398	599	733	900
150	6"	700	1225	1855	2275	2800
200	8"	1860	3145	4687	5715	

Working pressure and temperature

Max. working pressure

PN rated valves

Stainless steel body (CF8M)

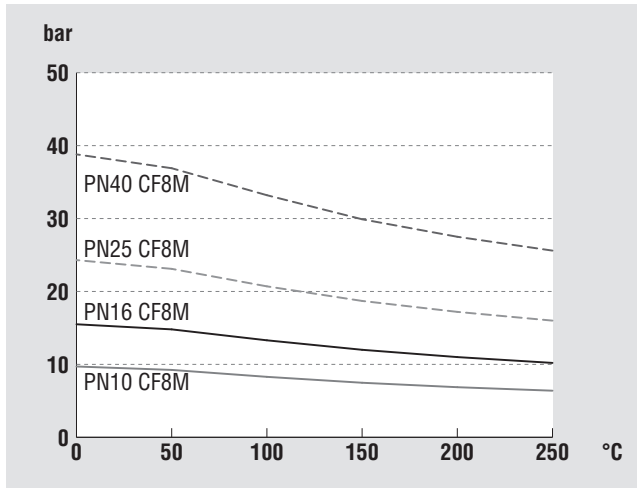

ANSI rated valves

Stainless steel body (CF8M)

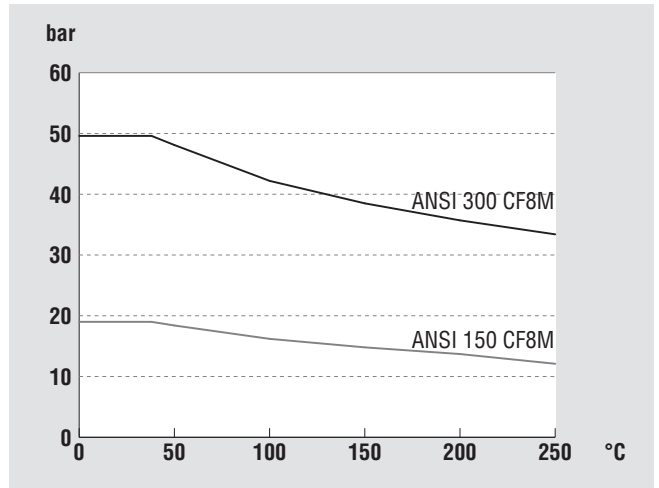

Differential pressure and temperature

The maximum allowed differential pressure (dp) is based on high torque requirements which are commonly witnessed in applications where the Duball DL Pocket Valve is used. The maximum allowed differential pressure is determined by the size of the valve, the temperature and the stem material.

The maximum allowed differential pressure can be further reduced if the maximum allowed working pressure (based on valve body material and pressure class) is lower than the maximum allowed differential pressure.

Max. dp standard stem (1.4460)

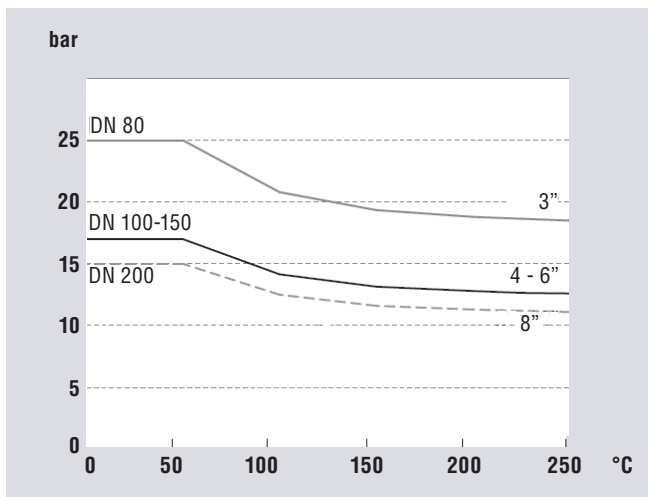

Max. dp high torque stem (17-4PH)

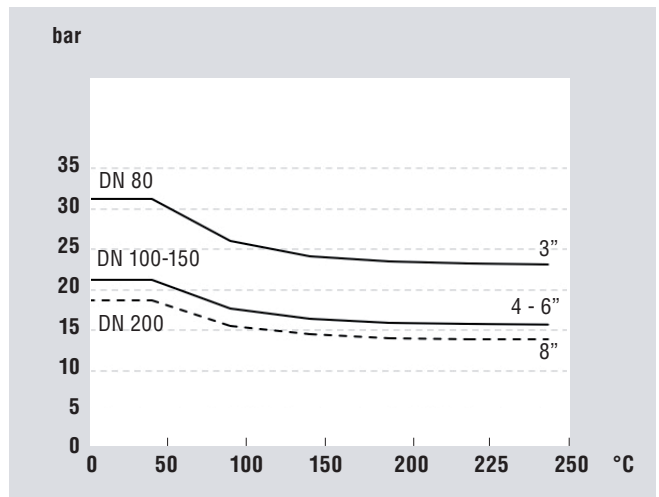

Dimensions and weight

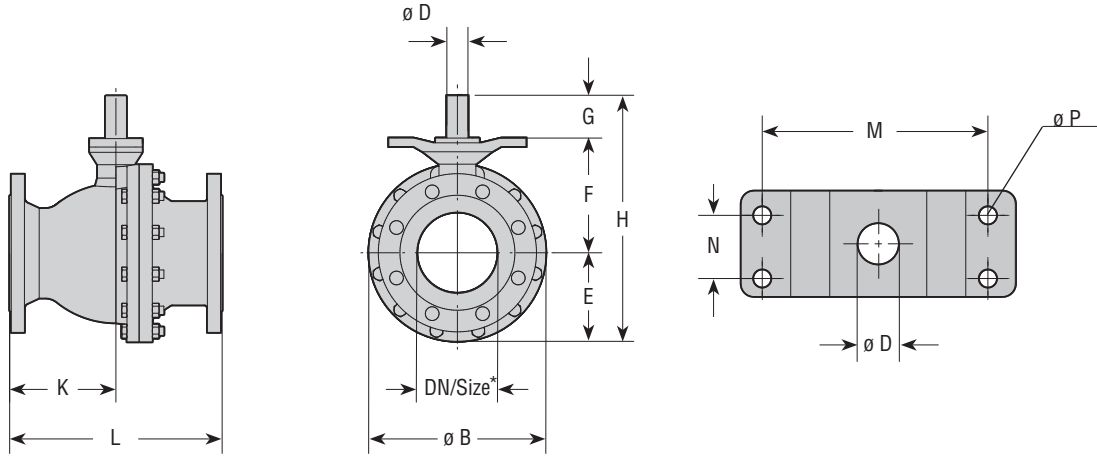

* Indicates nominal valve size

Table 3: Common dimensions - all pressure classes

DN	Size	Dimensions, mm								
		B	D	E	F	G	H	M	N	P
80	3"	214	25	107	137	50	284	115	30	11
100	4"	244	25	122	152	50	324	115	30	11
150	6"	336	40	168	218	80	466	214	60	18
200	8"	452	50	226	268	93	587	214	60	18

Table 4 : Pressure class related dimensions and weights

DN	Size	Dimensions, mm																	
		PN10			PN16			PN25			PN40			ANSI 150			ANSI 300		
		K	L	Weight kg	K	L	Weight kg	K	L	Weight kg	K	L	Weight kg	K	L	Weight kg	K	L	Weight kg
80	3"				121	241	27				142	283	32	102	203	28	142	283	34
100	4"	Identical to PN16 Choose PN16			153	305	39	Identical to PN40 Choose PN40			153	305	44	107	229	40	153	305	50
150	6"				197	394	96				202	403	110	197	394	101	202	403	117
200	8"	229	457	185	229	457	185	251	502	212	251	502	223	229	457	188	210	419	217

Actuators and accessories

The NAF Duball DL Pocket Valve provides optimum performance when teamed with an Automax 180° pneumatic actuator set to a stroke of 140°. Actuator sizing is determined by the valve size and process data. Table 5 shows the correct Automax actuator size to be selected based on valve size, supply pressure to the actuator and the maximum dp.

For larger valves and higher differential pressures, a severe service electric actuator can be used. Please consult Flowserve NAF for further information.

The Pocket Valve is to be equipped with two on/off valves and solenoid valves that are mounted on the two flush connections on the valve body.

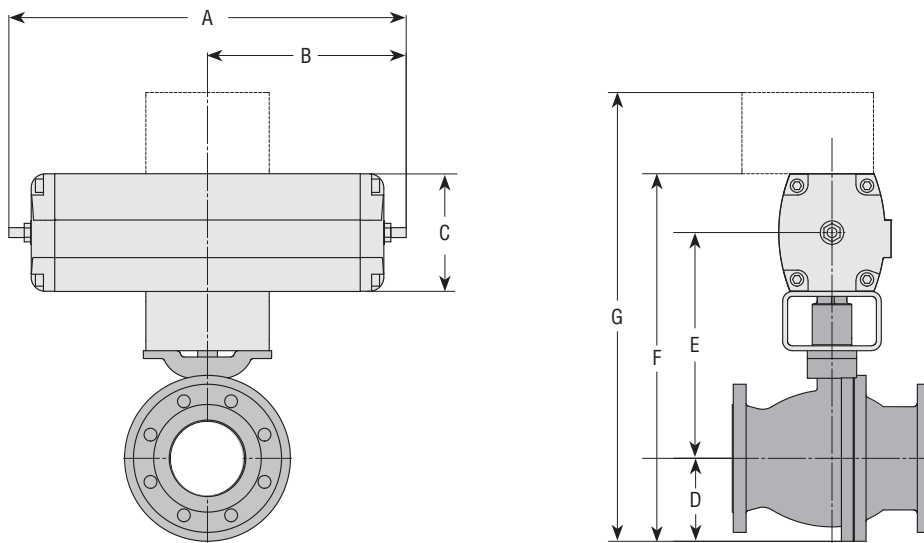

Table 5 : NAF Duball DL Pocket valves with Automax 180° pneumatic actuators (double acting)

DN	Size	Max. dP ¹⁾ bar at supply			Automax No.	Dimensions, mm							Weight kg ²⁾
		4 bar	5 bar	6 bar		A	B	C	D	E	F	G ³⁾	
80	3"	15	19.5	24	S150M	640	320	174	107	304	391	648	54
100	4"	7	9.5	12	S150M	640	320	174	122	309	396	668	66
100	4"	12	15	18	S175M	726	363	209	122	326,5	431	703	79
150	6"	-	6	7.5	S200M	805	402,5	239	168	457,5	577	895	155
150	6"	11	14.5	18	SN250M	995	497,5	280	168	478	618	936	176
200	8"	-	-	6	SN250M	995	497,5	280	226	528	668	1044	289
200	8"	6	8	10	SN300M	1118	559	340	226	558	728	1104	327

¹⁾ Includes a safety factor of 1.25

²⁾ Applies to average weight of a PN40 valve, mounting kit and Automax actuator

³⁾ Including 150 mm for the height of an average switch box

Product Code for NAF Duball DL Pocket Valve

Example:

88 8 4 K F - 0006 - BBA H E A - P
 Code 1 2 3 4 5 6 7 8 9 10 11

1. **Valve type**
88 NAF Duball DL

2. **Material**
8 CF8M

3. **Pressure rating**

2	PN 10	(DN 200) ¹⁾
3	PN 16	(DN 80–200)
4	ANSI Class 150	(Size 3”–8”)
5	PN 25	(DN 200) ¹⁾
6	PN 40	(DN 80-200)
7	ANSI Class 300	(Size 3”-8”)

4. **Stem bearing**
K R-PTFE, Carbon reinforced

5. **Body type**
F Flanged

6. **Size**

PN ratings		ANSI ratings	
	DN		Size
0080	80	0003	3”
0100	100	0004	4”
0150	150	0006	6”
0200	200	0008	8”

7. **Seat, ball and ball overlay**

BBA	Seat	Ball	Overlay
	Alloy 6 overlay/SS	Solid Alloy 6	-

8. **Seat seal**
H H-ELAST (same media resistance as EPDM), max t=250 °C

9. **Stem seal**
E Spring loaded R-PTFE V-rings, carbon reinforced

10. **Stem material**

A	Duplex EN 1.4460 (~AISI 329)
C	17-4PH

11. **Configuration**
P Pocket ball with locked and sealed seats.

Versions marked in **bold text** are the standard versions with the shortest leadtimes.

¹⁾ Sizes 80–150 have the same dimensions in PN 10 and PN 16. Choose PN 16 for these sizes.

Sizes 80–150 have the same dimensions in PN 25 and PN 40. Choose PN 40 for these sizes.

Intentionally left blank



NAF AB

SE-581 87 Linköping

Sweden

Telephone: +46 13 31 61 00

Facsimile: +46 13 13 60 54

e-mail: salesnaf@flowserve.com

Website: www.flowserve.com

www.naf.se

NFENTB4163-00-A4 11/17

To find your local Flowserve representative

or for more information about Flowserve Corporation,
visit www.flowserve.com or call USA 1 800 225 6989

Flowserve Corporation has established industry leadership in the design and manufacture of its products. When properly selected, this Flowserve product is designed to perform its intended function safely during its useful life. However, the purchaser or user of Flowserve products should be aware that Flowserve products might be used in numerous applications under a wide variety of industrial service conditions. Although Flowserve can (and often does) provide general guidelines, it cannot provide specific data and warnings for all possible applications. The purchaser/user must therefore assume the ultimate responsibility for the proper sizing and selection, installation, operation, and maintenance of Flowserve products. The purchaser/user should read and understand the Installation Operation Maintenance (IOM) instructions included with the product, and train its employees and contractors in the safe use of Flowserve products in connection with the specific application.

While the information and specifications contained in this literature are believed to be accurate, they are supplied for informative purposes only and should not be considered certified or as a guarantee of satisfactory results by reliance thereon. Nothing contained herein is to be construed as a warranty or guarantee, express or implied, regarding any matter with respect to this product. Because Flowserve is continually improving and upgrading its product design, the specifications, dimensions and information contained herein are subject to change without notice. Should any question arise concerning these provisions, the purchaser/user should contact Flowserve Corporation at any one of its worldwide operations or offices.

© 2017 Flowserve Corporation, Irving, Texas, USA. Flowserve is a registered trademark of Flowserve Corporation.